

TOP VIEW  
1:40

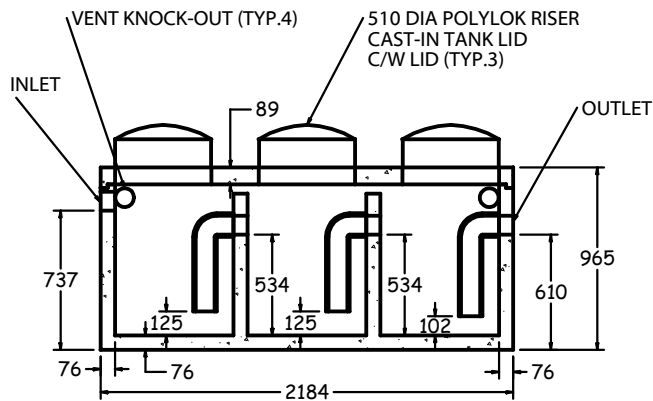

SIDE SECTION  
1:40

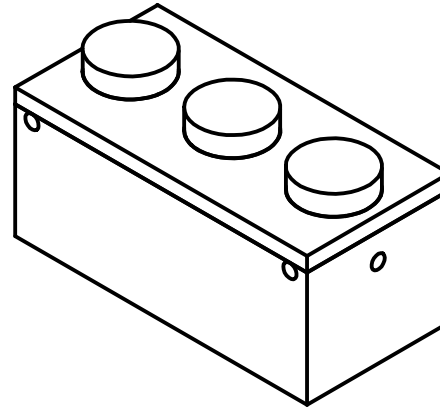
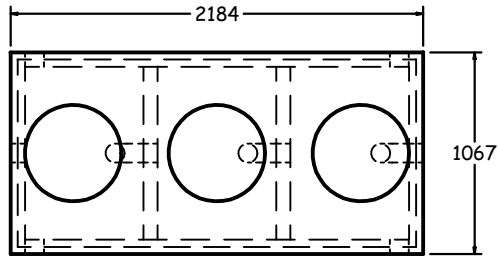
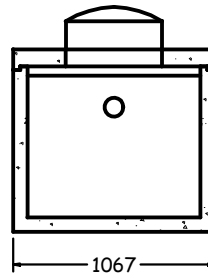

END SECTION  
1:40

## SPECIFICATIONS

ALL DIMENSIONS IN MILLIMETRES.

### NOM. CAPACITY:

200 GALLONS (909 LITRES) TO INVERT OF OUTLET.  
9.6 GALLONS/IN. VERTICALLY.  
941 LITRES/M VERTICALLY.

### CONCRETE:

35 MPa @ 28 DAYS,  
6% AIR ENTRAINMENT IN ACCORDANCE  
WITH CSA A23.1 MOD-M90

### REINFORCING:

IN ACCORDANCE WITH CSA A23.1-M90  
ALL REINFORCING STEEL HAS 30mm MIN. COVER.

### BAFFLES:

100mm DIA PVC SDR-35 PLASTIC PIPE  
LOCKED INTO CONCRETE.

### INLET & OUTLET:

100mm DIA PVC SDR-35 COUPLER  
CAST-IN TANK WALL.

### WEIGHT:

BOTTOM	-1636 KG
TOP SLAB	-432 KG

### NOTES:

REINFORCING DETAILS AVAILABLE UPON REQUEST.

VARIABLE OPENINGS IN TOP SLAB  
AVAILABLE UPON REQUEST.

MAX. BURIAL DEPTH: 610mm.  
DEEP BURIAL DEPTHS AND VEHICULAR LOAD TANKS  
AVAILABLE UPON REQUEST.

REFER TO INSTALLATION GUIDELINES FOR TANKS.

## 900 LITRE (200 GAL) OIL SEPARATOR (OG1000)



1645 SYDENHAM RD.  
KINGSTON, ONT.

PHONE:  
(800) 223-0012  
1-613-546-6683

[www.anchorconcrete.com](http://www.anchorconcrete.com)