

TOP VIEW
1:40

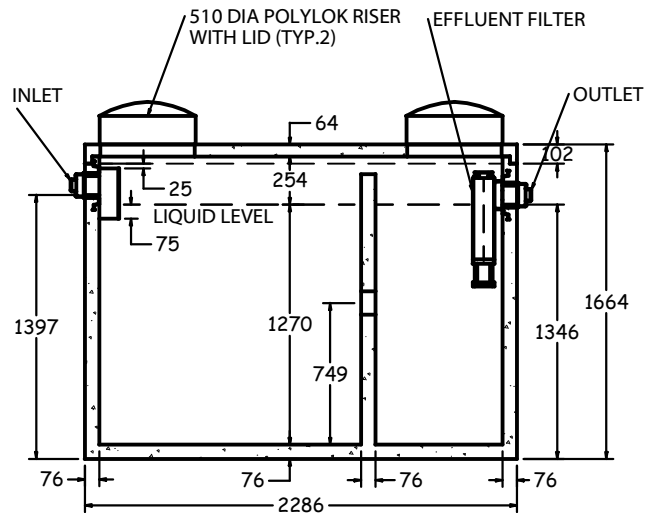

SIDE SECTION
1:40

PRESS-SEAL E-Z STIK
BUYTL MASTIC SEALANT

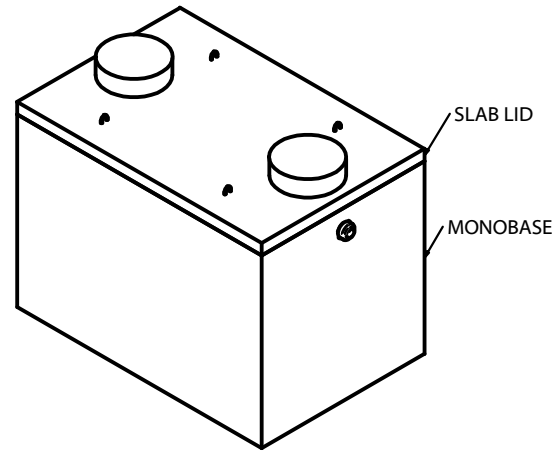
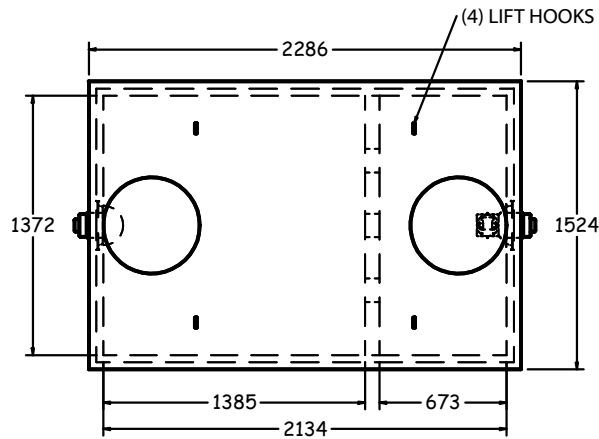
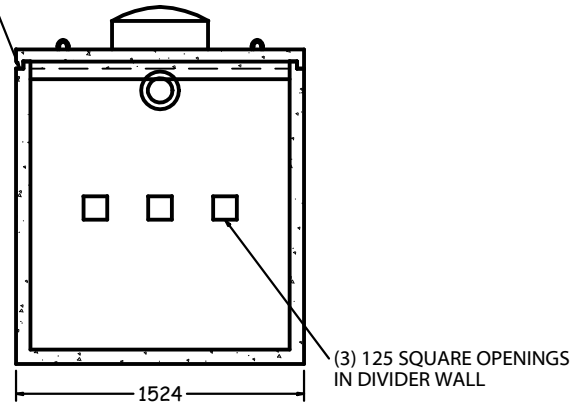

END SECTION
1:40

800 GALLON STD SEPTIC TANK (ST2000)

SPECIFICATIONS

ALL DIMENSIONS IN MILLIMETRES.

NOM. CAPACITY:

800 GALLONS (3637 LITRES) TO INVERT OF OUTLET.
15.1 GALLONS/IN. VERTICALLY.
2702 LITRES/M VERTICALLY.

CONCRETE:

35 MPa @ 28 DAYS,
6% AIR ENTRAINMENT IN ACCORDANCE
WITH CSA A23.1 MOD-M90

REINFORCING:

IN ACCORDANCE WITH CSA A23.1-M90
ALL REINFORCING STEEL HAS 30mm MIN. COVER.
REINFORCING DETAILS AVAILABLE UPON REQUEST.

BAFFLES:

PVC PLASTIC LOCKED INTO CONCRETE.

INLET & OUTLET:

LOW PRESSURE PIPE SEALS FOR
51 (2"), 76 (3") OR 102 (4") PIPE
(INVERT AT SAME ELEVATION).

WEIGHT:

BOTTOM	-2994 KG
TOP SLAB	-524 KG

NOTES:

MANUFACTURED IN ACCORDANCE WITH OPSS 1351.

MONOBASE INCLUDES SWIFT LIFT LIFTING ANCHORS.

VARIABLE OPENINGS IN TOP SLAB
AVAILABLE UPON REQUEST.

MAX. BURIAL DEPTH: 610mm.
DEEP BURIAL DEPTHS AVAILABLE UPON REQUEST.

ABOVE GROUND INSTALLATION NOT PERMITTED.
REFER TO INSTALLATION GUIDELINES FOR TANKS.



1645 SYDENHAM RD.
KINGSTON, ONT.

PHONE:
(800) 223-0012
1-613-546-6683

www.anchorconcrete.com