

SPECIFICATIONS

ALL DIMENSIONS IN MILLIMETRES.

NOM. CAPACITY:

1350 GALLONS (6100 LITRES) TO INVERT OF OUTLET.
28.4 GALLONS/IN. VERTICALLY.
5514 LITRES/M VERTICALLY.

CONCRETE:

35 MPa @ 28 DAYS,
6% AIR ENTRAINMENT IN ACCORDANCE
WITH CSA A23.1 MOD-M90

REINFORCING:

IN ACCORDANCE WITH CSA A23.1-M90
ALL REINFORCING STEEL HAS 30mm MIN. COVER.
REINFORCING DETAILS AVAILABLE UPON REQUEST.

BAFFLES:

INLET: PVC PLASTIC LOCKED INTO CONCRETE.

INLET & OUTLET:

POLYLOK TYPE III PIPE SEALS FOR
51 (2'), 76 (3") OR 102 (4") PIPE

WEIGHT:

BOTTOM	-14604 KG
TOP SLAB	-6062 KG

NOTES:

MAX. BURIAL DEPTH: 610mm.
DEEP BURIAL TANKS AVAILABLE UPON REQUEST.

ABOVE GROUND INSTALLATION NOT PERMITTED.
REFER TO INSTALLATION GUIDELINES FOR TANKS.

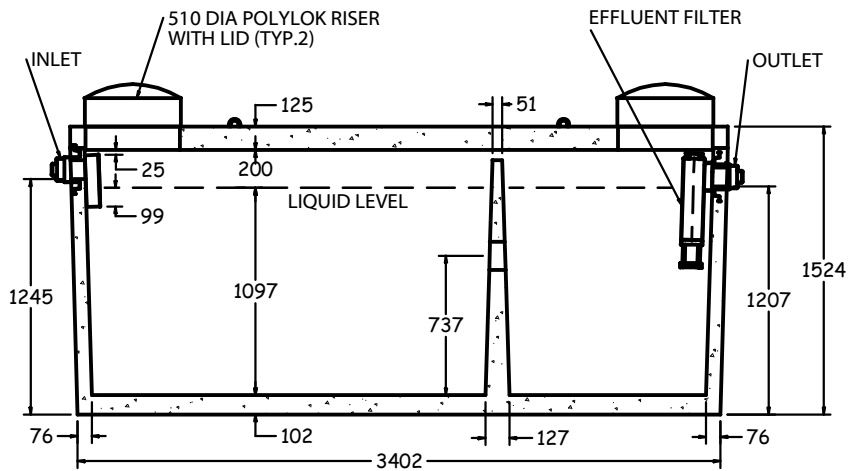
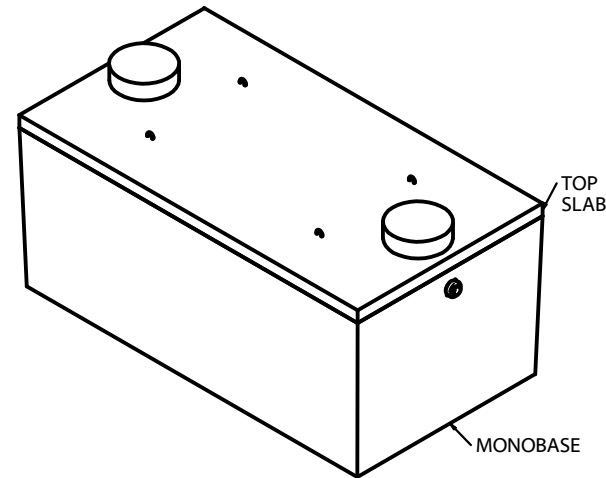
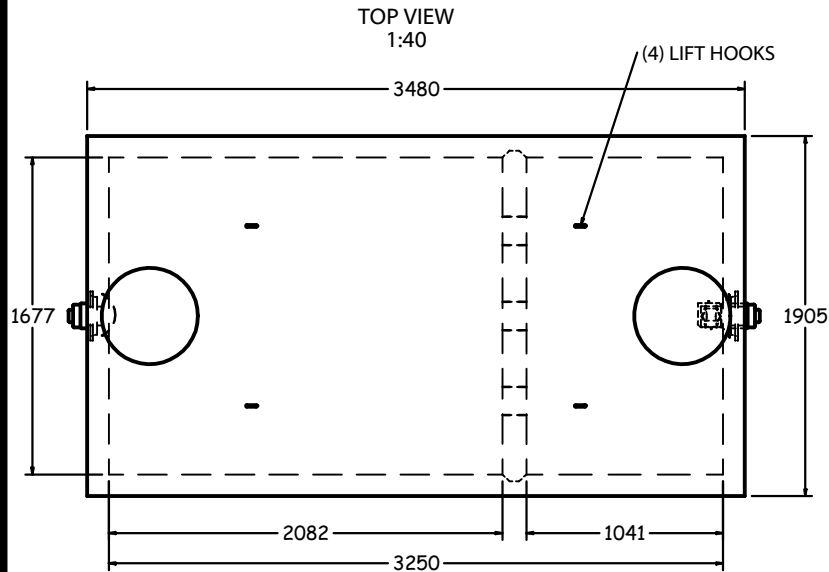

SIDE SECTION
1:40

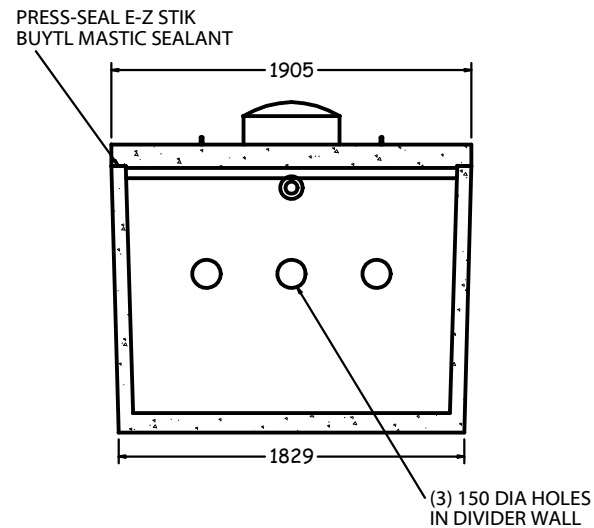

END SECTION
1:40

1350 GAL (6100L) STD SEPTIC TANK (ST2000)



1645 SYDENHAM RD.
KINGSTON, ONT.

PHONE:
(800) 223-0012
1-613-546-6683

www.anchorconcrete.com