

TOP VIEW
1:25

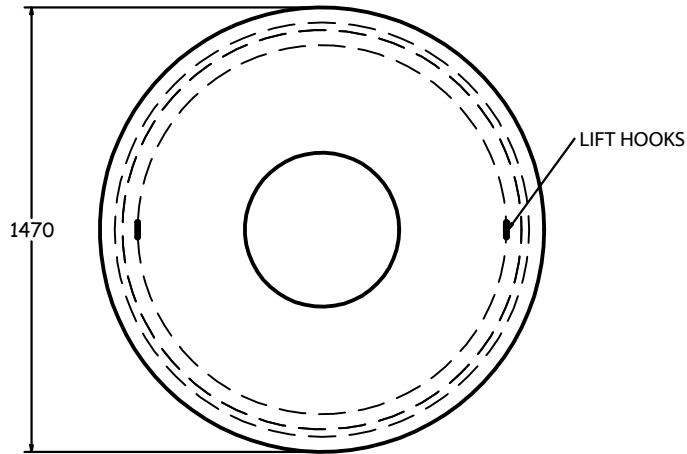

SPECIFICATIONS

ALL DIMENSIONS IN MILLIMETRES.

NOM. CAPACITY:

6.5 GALLONS/IN. VERTICALLY.
1163.3 LITRES/M VERTICALLY.

CONCRETE:

35 MPa @ 28 DAYS,
6% AIR ENTRAINMENT IN ACCORDANCE
WITH CSA A23.1 MOD-M90

WEIGHT:

LID	- 432 KG
RISER	- 1268 KG/VERTICAL M
FOR 305 (12")	- 175 KG (386 LB.)
FOR 610 (24")	- 773 KG (351 LB.)
FOR 914 (36")	- 1159 KG (526 LB.)
FOR 1219 (48")	- 1546 KG (703 LB.)
FOR 1829 (72")	- 2319 KG (1054 LB.)

NOTES:

RISERS INCLUDE SWIFT LIFT LIFTING ANCHORS.
CAPS INCLUDE LIFT HOOKS.

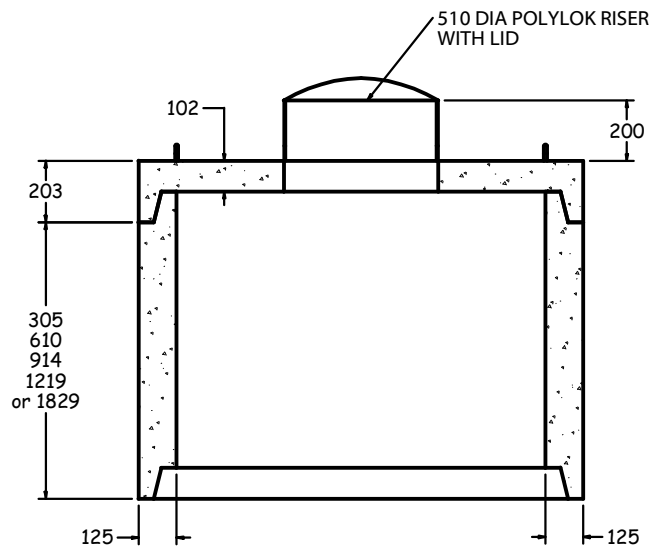

SIDE SECTION
1:25

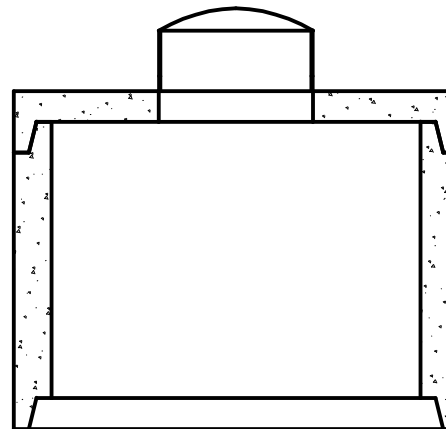

FRONT SECTION
1:25

48" (1219) DIA WELL TILE (WT1000)



1645 SYDENHAM RD.
KINGSTON, ONT.

PHONE:
(800) 223-0012
1-613-546-6683

www.anchorconcrete.com