

OPTIONS AVAILABLE UPON REQUEST INCLUDE:

SOLID BASE
DUCT TERMINATORS
CAST-IN PULLING EYES
CAST IRON EMBOSSED W/ ELECTRICAL OR COMMUNICATION

SPECIFICATIONS

ALL DIMENSIONS IN MILLIMETRES.

CONCRETE:

35 MPa @ 28 DAYS,
6% AIR ENTRAINMENT IN ACCORDANCE
WITH CSA A23.1 MOD-M90

REINFORCING:

IN ACCORDANCE WITH CSA A23.1-M90
ALL REINFORCING STEEL HAS 30mm MIN. COVER

WEIGHT:

1100 KG

NOTES:

PRODUCT MANUFACTURED TO C.H.B.D.C. LOADING.

MANUFACTURED IN ACCORDANCE WITH
OPSD 2112.040.

REINFORCING DETAILS AVAILABLE UPON REQUEST.

INCLUDES SWIFT LIFT LIFTING ANCHORS.

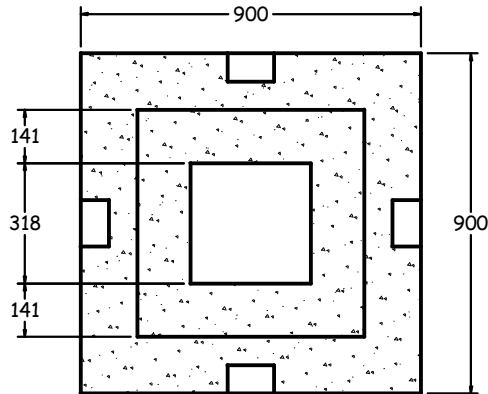

SECTION VIEW
1:20

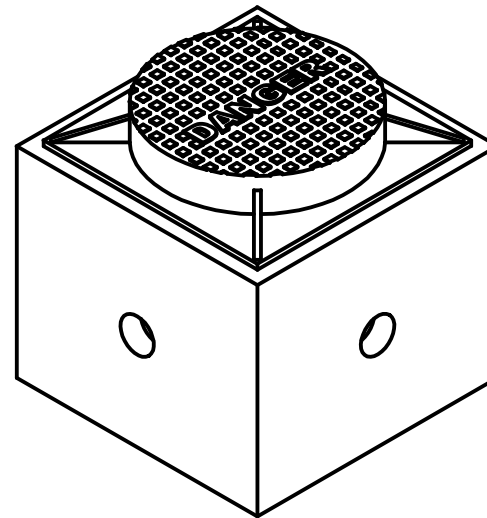

ISOMETRIC VIEW
1:20

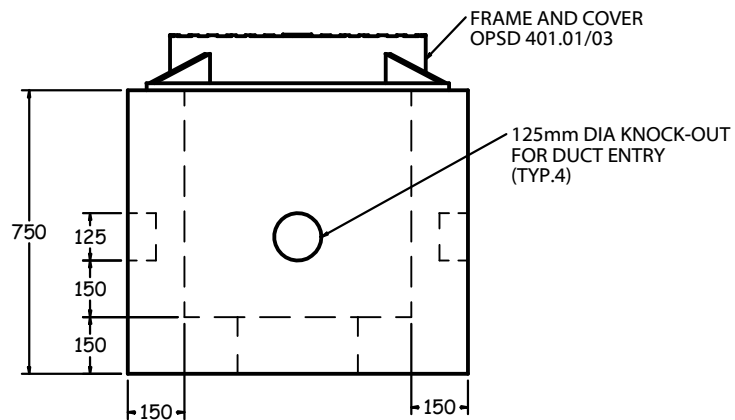

FRONT VIEW
1:20

600mmx600mm ELECTRICAL HANDHOLE (EL1000)



1645 SYDENHAM RD.
KINGSTON, ONT.

PHONE:
(800) 223-0012
1-613-546-6683

www.anchorconcrete.com