

TOP VIEW
1:30

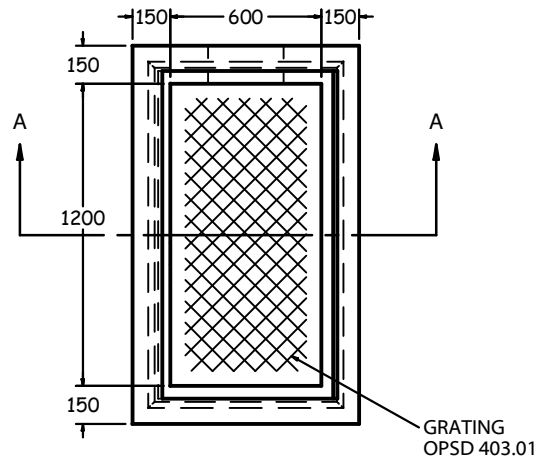

GRATING
OPSD 403.01

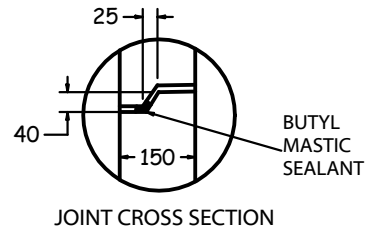

JOINT CROSS SECTION

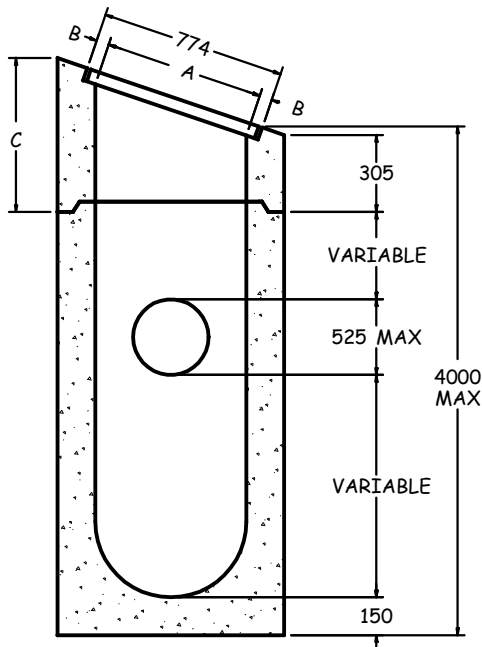

SECTION A-A
1:30

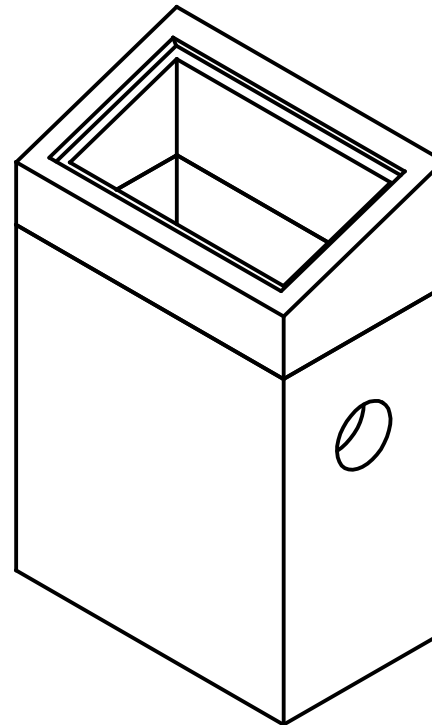

ISOMETRIC VIEW
1:30

SPECIFICATIONS

ALL DIMENSIONS IN MILLIMETRES.

CONCRETE:

35 MPa @ 28 DAYS,
6% AIR ENTRAINMENT IN ACCORDANCE
WITH CSA A23.1 MOD-M90

REINFORCING:

IN ACCORDANCE WITH CSA A23.1-M90
ALL REINFORCING STEEL HAS 30mm MIN. COVER

WEIGHT:

WALLS -1512 KG/V.M.
MONOBASE -264 KG

NOTES:

PRODUCT MANUFACTURED TO O.P.S.D. 705.040 TYPE A.

MANUFACTURED IN ACCORDANCE WITH OPSS 1351.

REINFORCING DETAILS AVAILABLE UPON REQUEST.

ALL PIECES INCLUDE SWIFT LIFT LIFTING ANCHORS.

OPTIONS AVAILABLE UPON REQUEST INCLUDE:

- PIPE GASKETS
- CAST-IN SUB-DRAIN COUPLERS
- DRILLED WEEP HOLES.

GRATE		DIMENSIONS		
TYPE	SLOPE	A	B	C
B	2:1	670	52	755
B	3:1	632	71	610
B	4:1	618	78	530
B	HOR	600	87	305

600x1200mm DITCH INLET TYPE A (DI1200)



1645 SYDENHAM RD.
KINGSTON, ONT.

PHONE:
(800) 223-0012
1-613-546-6683

www.anchorconcrete.com