

TOP VIEW
1:30

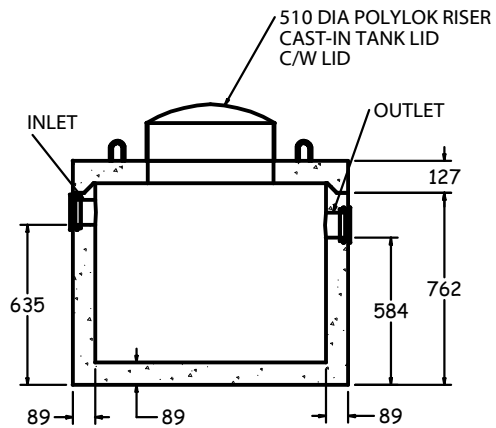

FRONT VIEW
1:30

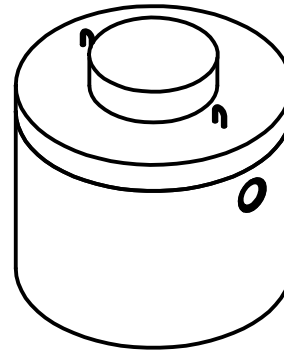
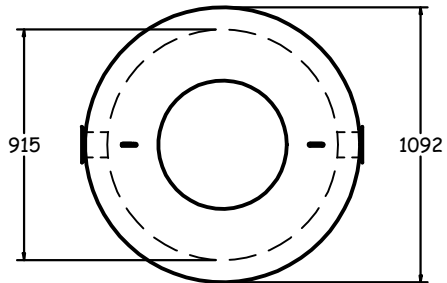
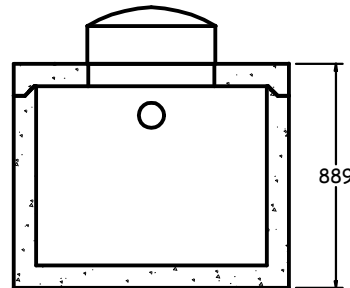

END VIEW
1:30

75 GALLON PUMP TANK (ST2000)

SPECIFICATIONS

ALL DIMENSIONS IN MILLIMETRES.

NOM. CAPACITY:

100 GALLONS TOTAL (454 LITRES).
70 GALLONS (318 LITRES) TO INVERT OF OUTLET.
3.7 GALLONS/IN. VERTICALLY.
642 LITRES/M VERTICALLY.

CONCRETE:

35 MPa @ 28 DAYS,
6% AIR ENTRAINMENT IN ACCORDANCE
WITH CSA A23.1 MOD-M90

REINFORCING:

IN ACCORDANCE WITH CSA A23.1-M90
ALL REINFORCING STEEL HAS 30mm MIN. COVER.

INLET & OUTLET:

LOW PRESSURE PIPE SEALS FOR 2"(51), 3"(76)
OR 4"(102) PIPE (INVERT AT SAME ELEVATION).

WEIGHT:

BOTTOM	-659 KG
TOP SLAB	-205 KG

NOTES:

REINFORCING DETAILS AVAILABLE UPON REQUEST.

ACTUAL PUMPING VOLUME DEPENDS ON
THE PUMP'S FLOAT SETTINGS.



1645 SYDENHAM RD.
KINGSTON, ONT.

PHONE:
(800) 223-0012
1-613-546-6683

www.anchorconcrete.com