

TOP VIEW
1:60

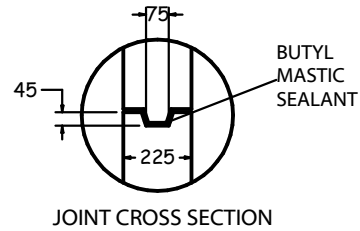
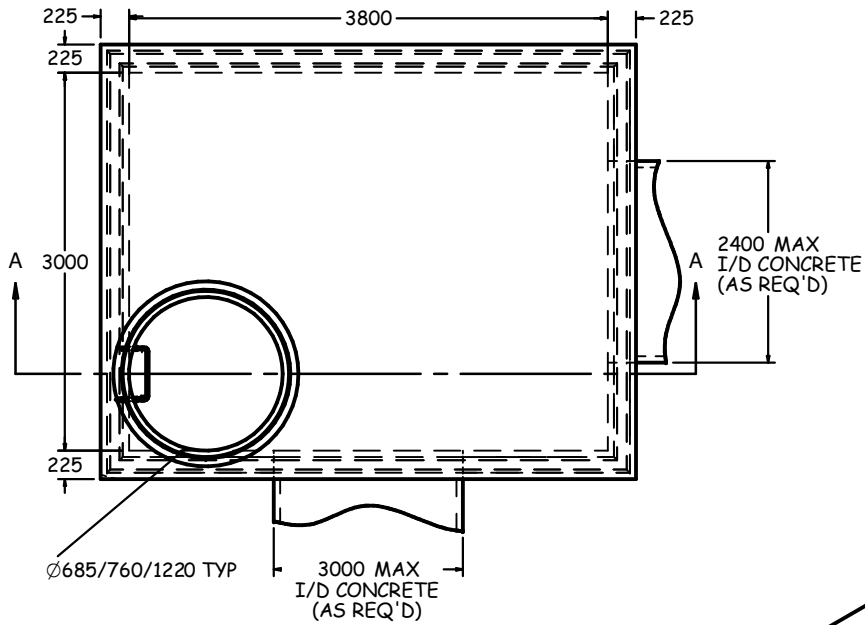

SPECIFICATIONS

ALL DIMENSIONS IN MILLIMETRES.

CONCRETE:

45 MPa @ 28 DAYS,
6% AIR ENTRAINMENT IN ACCORDANCE
WITH CSA A23.1 MOD-M90

REINFORCING:

IN ACCORDANCE WITH CSA A23.1-M90
ALL REINFORCING STEEL HAS 30mm MIN. COVER

WEIGHT:

| | |
|---------------|---------------|
| WALLS | -7830 KG/V.M. |
| MONO BASE/TOP | -8208 KG |
| TOP SLAB | -10557 KG |

NOTES:

PRODUCT MANUFACTURED TO OBC & C.H.B.D.C.
LOADINGS AS APPLICABLE.

MANUFACTURED IN ACCORDANCE WITH OPSS 1351.

REINFORCING DETAILS AVAILABLE UPON REQUEST.

ALL PIECES INCLUDE SWIFT LIFT LIFTING ANCHORS.

ALL MAINTENANCE HOLES INCLUDE
HOLLOW ALUMINUM LADDER RUNGS
AS PER OPSD 405.010.

SUMP AVAILABLE UPON REQUEST.

VARIABLE OPENINGS IN TOP SLAB
AVAILABLE UPON REQUEST.

MAX. BURIAL DEPTH: 900mm.
DEEP BURIAL DEPTHS AVAILABLE UPON REQUEST.

REFER TO DRAWING MH-3 FOR MAX. PIPE SIZES.
PIPE GASKETS AVAILABLE UPON REQUEST.

REFER TO INSTALLATION GUIDELINES
FOR BOX MANHOLES AND CHAMBERS.

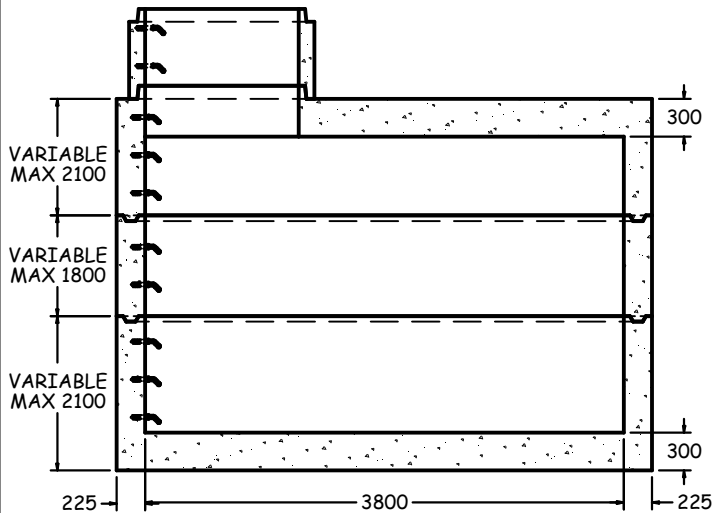

SECTION A-A
1:60

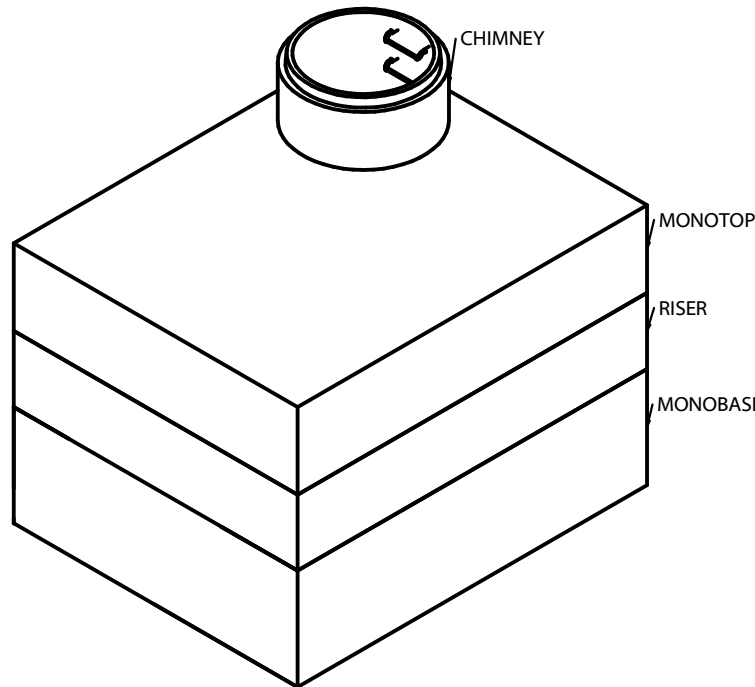

ISOMETRIC VIEW
1:65

3000x3800 BOX MANHOLE (BM3000)



1645 SYDENHAM RD.
KINGSTON, ONT.

PHONE:
(800) 223-0012
1-613-546-6683

www.anchorconcrete.com