

TOP VIEW
1:40

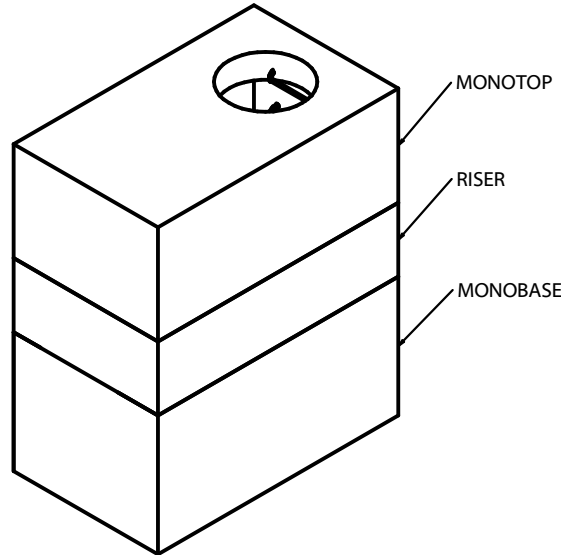
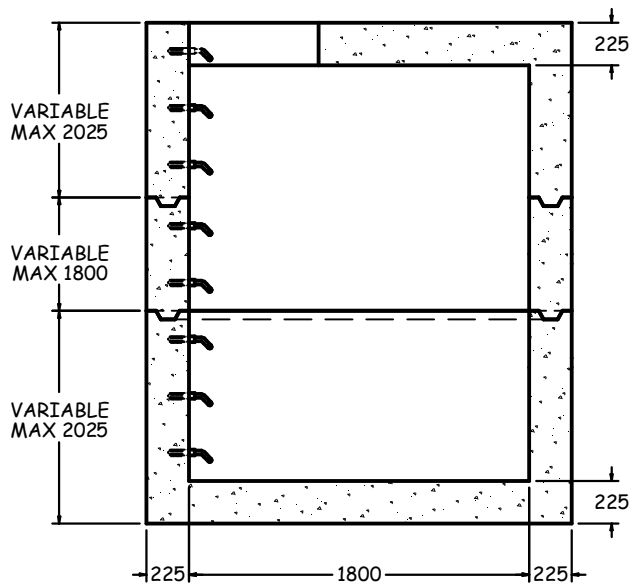
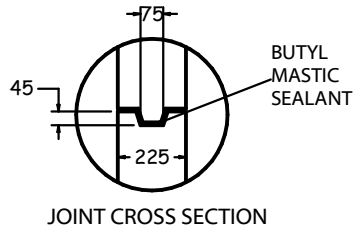
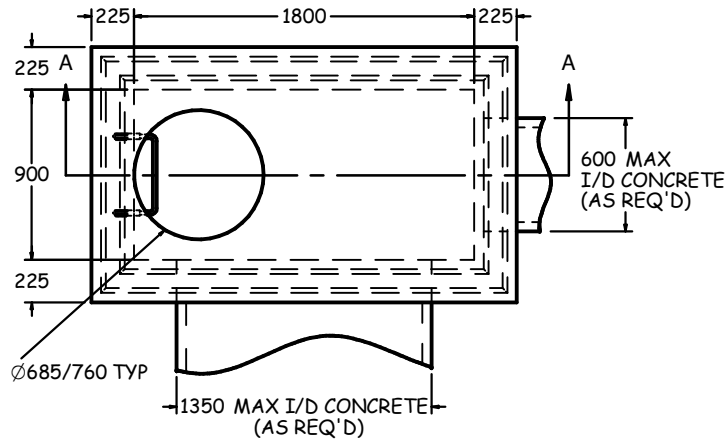

ISOMETRIC VIEW
1:50

SPECIFICATIONS

ALL DIMENSIONS IN MILLIMETRES.

CONCRETE:

45 MPa @ 28 DAYS,
6% AIR ENTRAINMENT IN ACCORDANCE
WITH CSA A23.1 MOD-M90

REINFORCING:

IN ACCORDANCE WITH CSA A23.1-M90
ALL REINFORCING STEEL HAS 30mm MIN. COVER

WEIGHT:

WALLS	-3402 KG/V.M.
MONO BASE/TOP	-875 KG
TOP SLAB	-1640 KG

NOTES:

PRODUCT MANUFACTURED TO OBC & C.H.B.D.C. LOADINGS
AS APPLICABLE.

MANUFACTURED IN ACCORDANCE WITH OPSS 1351.

REINFORCING DETAILS AVAILABLE UPON REQUEST.

ALL PIECES INCLUDE SWIFT LIFT LIFTING ANCHORS.

ALL MAINTENANCE HOLES INCLUDE
HOLLOW ALUMINUM LADDER RUNGS AS PER OPSD 405.010.

SUMP AVAILABLE UPON REQUEST.

VARIABLE OPENINGS IN TOP SLAB AVAILABLE UPON REQUEST.

MAX. BURIAL DEPTH: 900mm.
DEEP BURIAL DEPTHS AVAILABLE UPON REQUEST.

REFER TO DRAWING MH-3 FOR MAX. PIPE SIZES.
PIPE GASKETS AVAILABLE UPON REQUEST.

REFER TO INSTALLATION GUIDELINES
FOR BOX MANHOLES AND CHAMBERS.

900x1800 BOX MANHOLE (BM0900)



1645 SYDENHAM RD.
KINGSTON, ONT.

PHONE:
(800) 223-0012
1-613-546-6683

www.anchorconcrete.com