

**OPTIONS AVAILABLE UPON REQUEST INCLUDE:**

- DUCT TERMINATORS
- SUMP W/DRAIN
- CAST-IN PULLING EYES
- CAST-IN CABLE RACKS
- CAST IRON EMBOSSED W/ ELECTRICAL OR COMMUNICATION

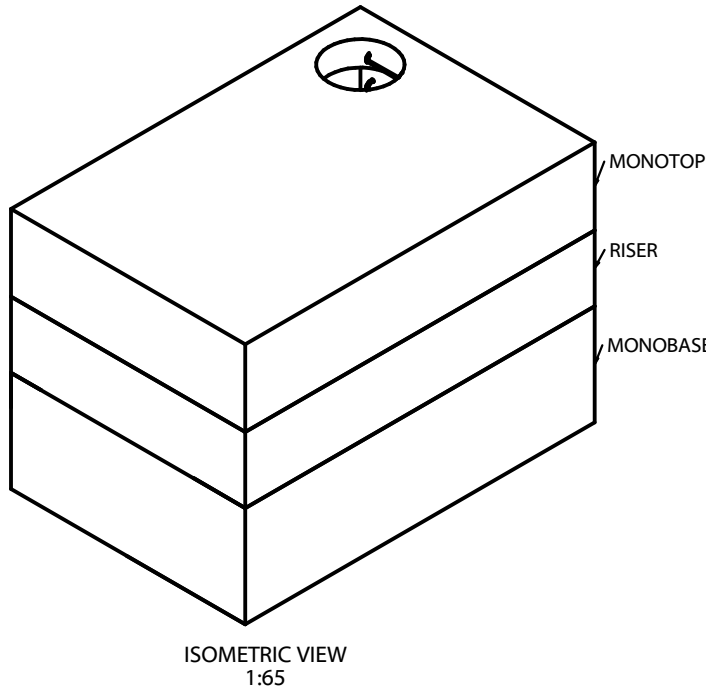
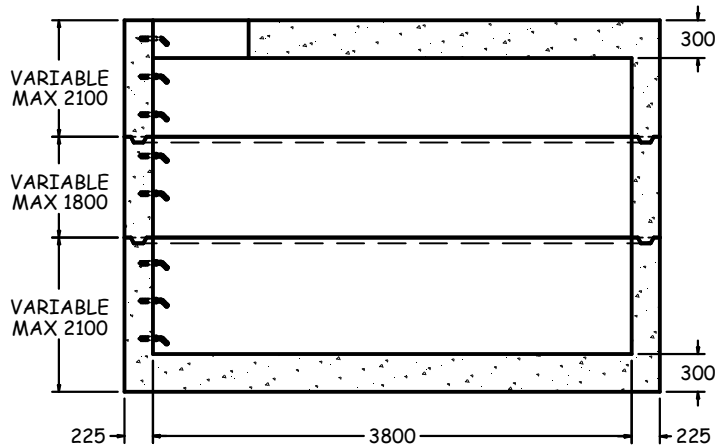
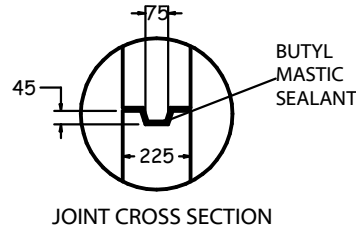
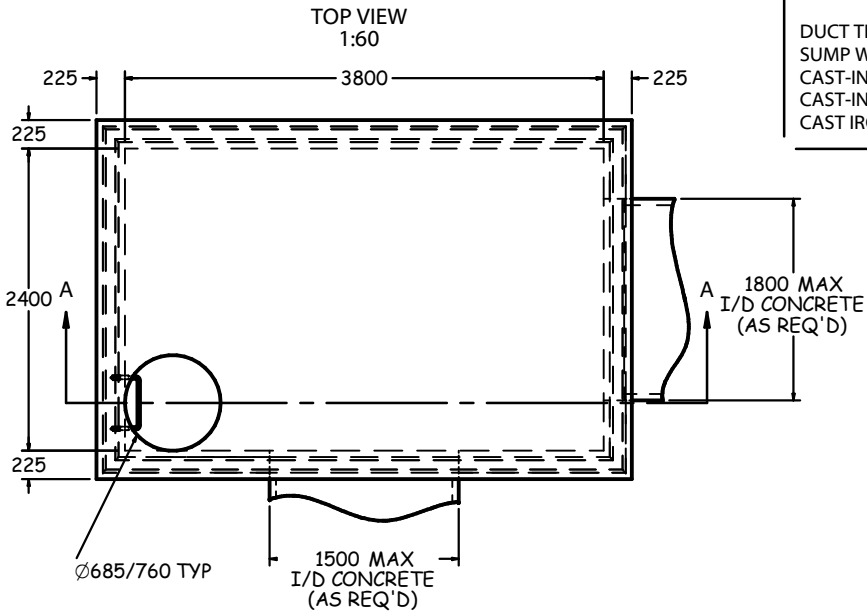

**SPECIFICATIONS**

ALL DIMENSIONS IN MILLIMETRES.

**CONCRETE:**

45 MPa @ 28 DAYS,  
6% AIR ENTRAINMENT IN ACCORDANCE  
WITH CSA A23.1 MOD-M90

**REINFORCING:**

IN ACCORDANCE WITH CSA A23.1-M90  
ALL REINFORCING STEEL HAS 30mm MIN. COVER

**WEIGHT:**

WALLS	-7182 KG/V.M.
MONO BASE/TOP	-6566 KG
TOP SLAB	-8721 KG

**NOTES:**

PRODUCT MANUFACTURED TO C.H.B.D.C. LOADING.

MANUFACTURED IN ACCORDANCE WITH OPSS 1351.

REINFORCING DETAILS AVAILABLE UPON REQUEST.

ALL PIECES INCLUDE SWIFT LIFT LIFTING ANCHORS.

ALL MAINTENANCE HOLES INCLUDE  
SOLID ALUMINUM LADDER RUNGS  
AS PER OPSD 405.020.

VARIABLE OPENINGS IN TOP SLAB  
AVAILABLE UPON REQUEST.

MAX. BURIAL DEPTH: 900mm.  
DEEP BURIAL DEPTHS AVAILABLE UPON REQUEST.

REFER TO DRAWING MH-3 FOR MAX. PIPE SIZES.  
PIPE GASKETS AVAILABLE UPON REQUEST.

REFER TO INSTALLATION GUIDELINES  
FOR BOX MANHOLES AND CHAMBERS.

**2400x3800 ELECTRICAL/COMMUNICATION MANHOLE (BM2400)**



1645 SYDENHAM RD.  
KINGSTON, ONT.

PHONE:  
(800) 223-0012  
1-613-546-6683

www.anchorconcrete.com