

## SPECIFICATIONS

ALL DIMENSIONS IN MILLIMETRES.

### CONCRETE:

35 MPa @ 28 DAYS,  
6% AIR ENTRAINMENT IN ACCORDANCE  
WITH OPSD 920.012

### REINFORCING:

IN ACCORDANCE WITH CSA G30.12  
ALL REINFORCING STEEL HAS 30mm MIN. COVER

### WEIGHT:

1308 KG

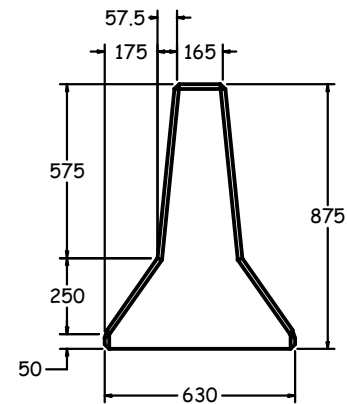
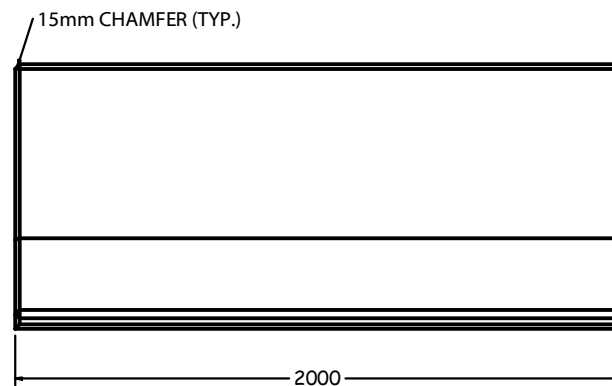
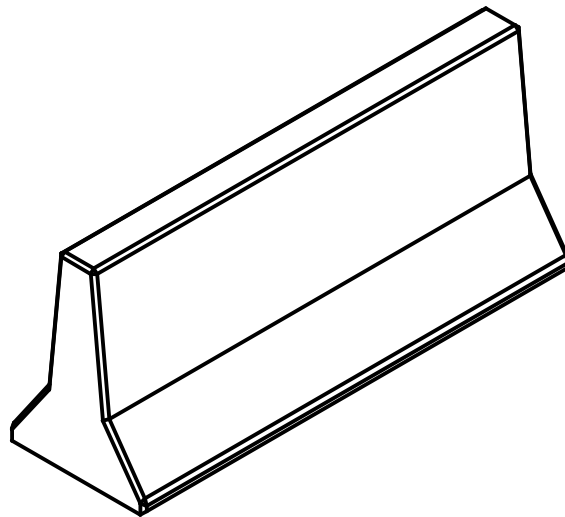

**HALF SIZE BARRIER (TS1000)**



1645 SYDENHAM RD.  
KINGSTON, ONT.

PHONE:  
(800) 223-0012  
1-613-546-6683

[www.anchorconcrete.com](http://www.anchorconcrete.com)