

SPECIFICATIONS

ALL DIMENSIONS IN MILLIMETRES.

NOM. CAPACITY:

1500 GALLONS (6820 LITRES) TO INVERT OF OUTLET.
 31.8 GALLONS/IN. VERTICALLY.
 5680 LITRES/M VERTICALLY.

CONCRETE:

45 MPa @ 28 DAYS,
 6% AIR ENTRAINMENT IN ACCORDANCE
 WITH CSA A23.1 MOD-M90

REINFORCING:

IN ACCORDANCE WITH CSA A23.1-M90
 ALL REINFORCING STEEL HAS 30mm MIN. COVER.

BAFFLES:

100mm DIA PVC SDR-35 PLASTIC PIPE
 LOCKED INTO CONCRETE.

INLET & OUTLET:

100mm DIA PVC SDR-35 COUPLER CAST-IN TANK WALL

WEIGHT:

BOTTOM	-7690 KG
TOP SLAB	-2400 KG

NOTES:

MANUFACTURED IN ACCORDANCE WITH OPSS 1351.

REINFORCING DETAILS AVAILABLE UPON REQUEST.

ALL PIECES INCLUDE SWIFT LIFT LIFTING ANCHORS.

VARIABLE OPENINGS IN TOP SLAB
 AVAILABLE UPON REQUEST.

MAX. BURIAL DEPTH: 610mm.
 DEEP BURIAL DEPTHS AVAILABLE UPON REQUEST.

REFER TO INSTALLATION GUIDELINES FOR TANKS.

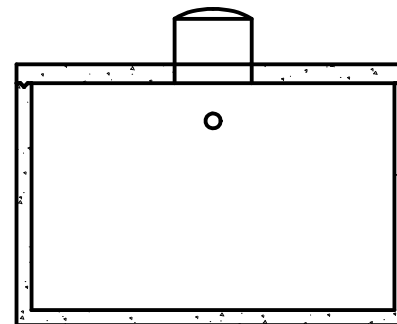
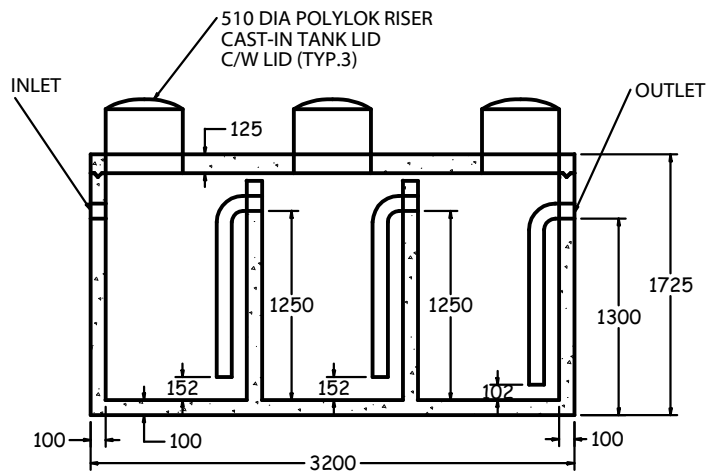
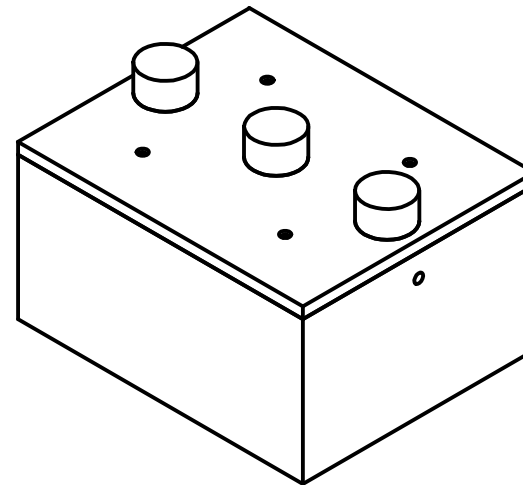
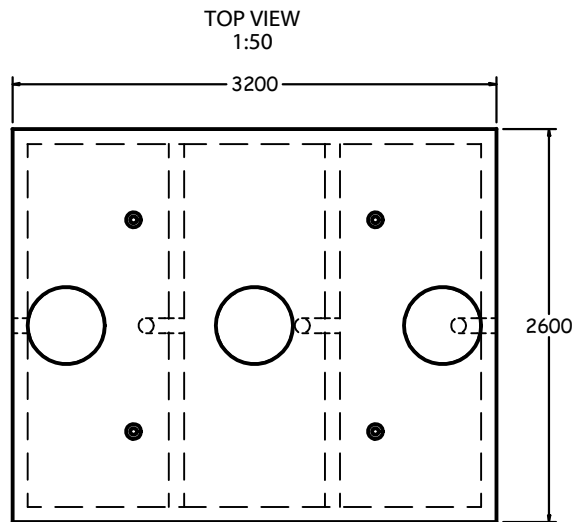

SIDE SECTION
1:50

END SECTION
1:50

6800 LITRE (1500 GAL) OIL SEPARATOR (OG1000)



1645 SYDENHAM RD.
 KINGSTON, ONT.

PHONE:
 (800) 223-0012
 1-613-546-6683

www.anchorconcrete.com