

TOP VIEW  
1:40

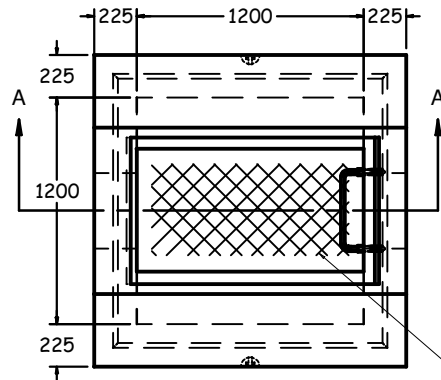

GRATING B OR C  
OPSD 403.01

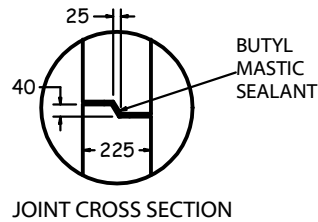

JOINT CROSS SECTION

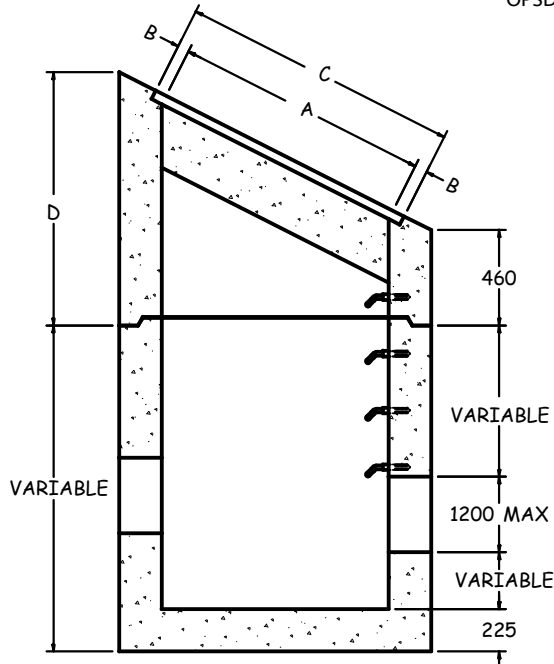

SECTION A-A  
1:40

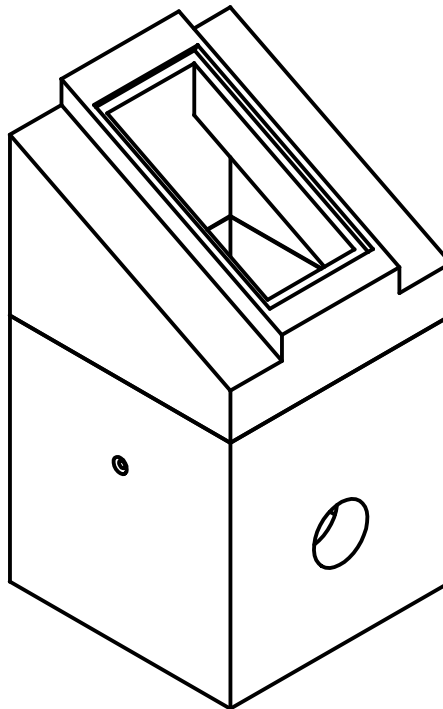

ISOMETRIC VIEW  
1:40

**SPECIFICATIONS**

ALL DIMENSIONS IN MILLIMETRES.

**CONCRETE:**

45 MPa @ 28 DAYS,  
6% AIR ENTRAINMENT IN ACCORDANCE  
WITH CSA A23.1 MOD-M90

**REINFORCING:**

IN ACCORDANCE WITH CSA A23.1-M90  
ALL REINFORCING STEEL HAS 30mm MIN. COVER

**WEIGHT:**

WALLS -3121 KG/V.M.  
MONOBASE -804 KG

**NOTES:**

- PRODUCT MANUFACTURED TO O.P.S.D. 705.050.
- MANUFACTURED IN ACCORDANCE WITH OPSS 1351.
- REINFORCING DETAILS AVAILABLE UPON REQUEST.
- ALL PIECES INCLUDE SWIFT LIFT LIFTING ANCHORS.
- ALL MAINTENANCE HOLES INCLUDE HOLLOW ALUMINUM LADDER RUNGS AS PER OPSD 405.010. MAX. HOLE SIZE @ 90° IS 1200mm.

**OPTIONS AVAILABLE UPON REQUEST INCLUDE:**

- PIPE GASKETS
- CAST-IN SUB-DRAIN COUPLERS
- DRILLED WEEP HOLES.

GRATE		DIMENSIONS			
TYPE	SLOPE	A	B	C	D
C	2:1	1341	66	1473	1295
	3:1	1265	104	1473	1017
	4:1	1237	118	1473	875
B	6:1	1216	65	1346	735
	8:1	1210	68	1346	669
	10:1	1206	70	1346	627
	HOR	1200	73	1346	460

**1200x1200mm DITCH INLET MANHOLE TYPE B (DI1200)**



1645 SYDENHAM RD.  
KINGSTON, ONT.

PHONE:  
(800) 223-0012  
1-613-546-6683

www.anchorconcrete.com