

SITE PREPARATION:

- A) ON LEVEL ASPHALT - NONE REQUIRED (BEARING PADS RECOMMENDED).
- B) ON GRASS BASE - CONSTRUCT THE BASE OF 150mm COMPACTED STONE WITH 50mm LOOSE STONE CHIPS ON TOP TO DIMENSIONS OF 3353x3353 (11'x11').

SPECIFICATIONS

BUILDING:

WALLS, ROOF AND BASE REINFORCED IN ACCORDANCE WITH CSA G30.18 (ALL REBAR HAS 30mm COVER).

CONCRETE: 35MPa @28 DAYS, 5-7% AIR ENT. AS PER CSA A23.4-00.

CAST-IN 16 GAUGE PAINTED STEEL DOOR FRAME.

TOTAL ROOF LOAD 5.9 KPa (MIN)
MAX WIND LOAD 0.6 KPa
TOTAL FLOOR LOAD 6.9 KPa.

AVAILABLE FINISHES:
EXPOSED AGGREGATE (NATURAL STONE FINISH)
OR
SMOOTH CONCRETE FINISH WALLS.

NO JOINTS BETWEEN WALLS OR BETWEEN WALL AND ROOF FOR SUPERIOR WEATHER PROTECTION.

DELIVERED AND PLACED AS ONE PIECE (NO SITE ASSEMBLY REQUIRED).

SEAL BETWEEN WALLS AND BASE IS A MAINTENANCE FREE BUTYL MASTIC SEALANT.

2 VENTS CAST-IN.

DOORS & HARDWARE:

914x2032x44 THICK HOLLOW METAL DOORS.

16 GA STEEL WITH ZINC BASE COAT AND EXTERIOR FINISH COAT.

SPOT WELDED EDGES AND INTERIOR STEEL STIFFENERS FOR IMPROVED VANDAL RESISTANCE.

THREE VANDAL-RESISTANT HINGES PER DOOR.

DOOR HAS A STEEL TOP CAP AND ALUMINUM AND FIBRE DOOR SWEEP.

HIGH QUALITY DEADBOLTSCHLAGE LOCK, 83T7K-STK-626 STANDARD.

KEYED ALIKE OPTIONS.

DOOR HAS A SPRING SOFTENED CHAIN CHECK.

ALUMINUM DRIP EDGE (ABOVE DOOR).

TOP VIEW
1:50

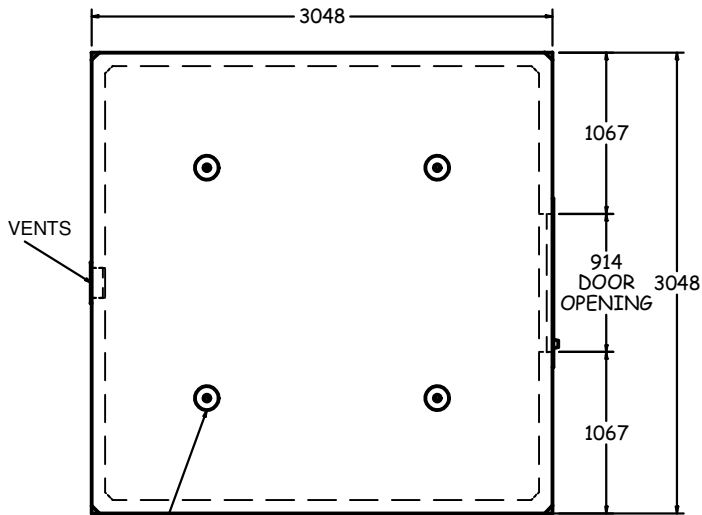

4 x 4-TONNE SWIFT LIFTS FOR PLACEMENT

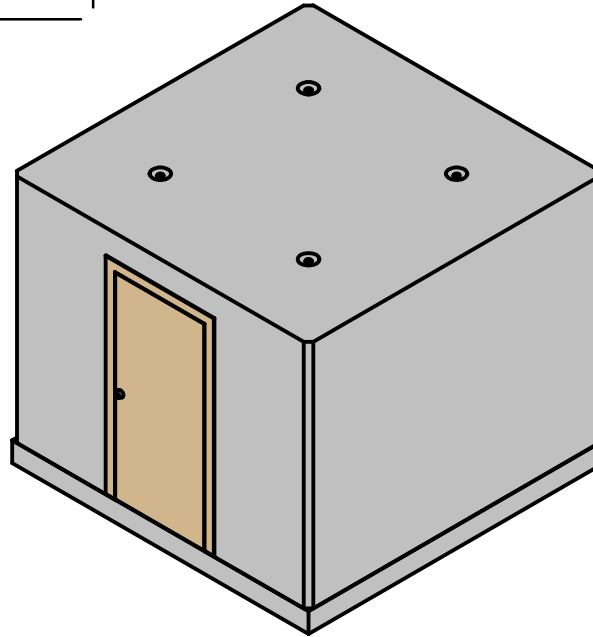

ELEVATION VIEW
1:50

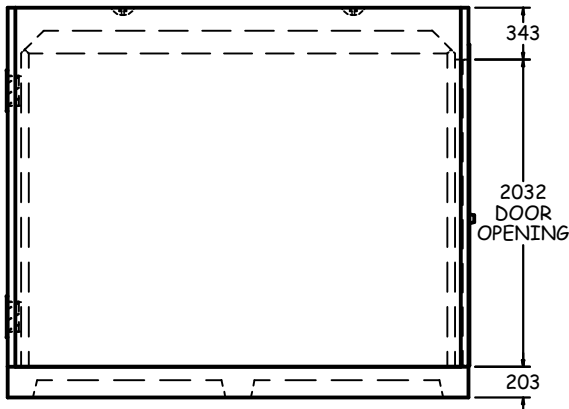

FRONT VIEW
1:50

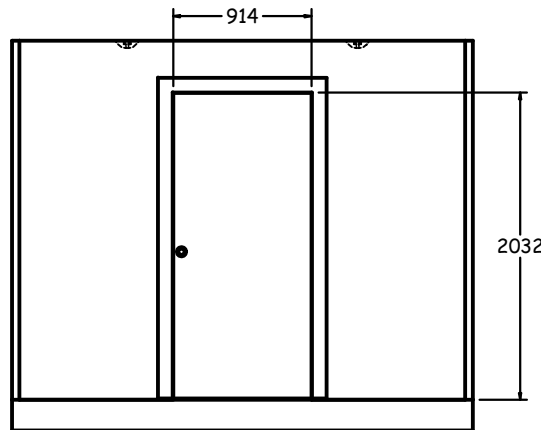

REDICAST 10 SERVICE BUILDING WITH SINGLE DOOR



1645 SYDENHAM RD.
KINGSTON, ONT.

PHONE:
(800) 223-0012
1-613-546-6683

www.anchorconcrete.com